

Estimating torsional demands in plan irregular buildings using pushover procedures coupled with linear dynamic response spectrum analysis

C. Bhatt¹ and R. Bento²

^{1,2} Instituto Superior Técnico, Technical University of Lisbon

Av. Rovisco Pais, 1049-001, Lisbon, Portugal

¹e-mail: cbhatt@civil.ist.utl.pt, ²e-mail: rbento@civil.ist.utl.pt

Abstract The limitation of the commonly used Nonlinear Static Procedures (NSPs), including the ones recommended by the seismic codes (Eurocode 8 - N2 method, ATC40 and FEMA440 – Capacity Spectrum Method, CSM) is their inability to capture the torsional behaviour of plan-asymmetric buildings. Fajfar and his team have extended the N2 method to this kind of structures through the application of correction factors which depend on both, linear dynamic response spectrum analysis and pushover analysis. In this paper, the proposed correction factors are applied to the N2 method and to the CSM with the features recommended in FEMA440 in order to assess the seismic response of three existing plan irregular buildings. The torsional demands estimated by the aforementioned NSPs are duly compared with the ones defined by means of the most precise nonlinear dynamic analyses for several levels of seismic intensity. The torsional correction factors used seem to improve the performance of existing code pushover methodologies in estimating the seismic response of plan irregular structures.

1 Introduction

The use of NSPs on the seismic assessment or design of structures has gained considerable popularity in recent years, backed by a large number of extensive verification studies that have demonstrated their relatively good accuracy in estimating the seismic response of regular structures (planar frames and bridges).

However, the extension of such use to the case of 3D irregular structures has been the object of a limited number of scientific studies, which effectively ends up by limiting significantly the use of NSPs to assess actual existing structures, the majority of which do tend to be non-regular [1, 2, 3, 4].

The major limitations of the existing NSPs, including the ones recommended by the seismic codes (e.g. the N2 method [5, 6] proposed in Eurocode 8 [7] and the CSM [8, 9] with the features presented in ATC40 [10] and in FEMA440 [11]), is their inability to capture the torsional behaviour of plan irregular buildings.

Generally they cannot capture the torsional effects distorting the real structural response.

Fajfar and his team have developed the Extended N2 method [1, 12] which is able to capture the torsional behaviour of plan-asymmetric buildings. This procedure is based on the application of correction factors to the pushover results obtained with the N2 method. The correction factors depend on the results of a dynamic elastic analysis and of a pushover analysis.

Bhatt and Bento have also extended the CSM-FEMA440 to plan asymmetric buildings [13] using the same correction factors definition proposed by Fajfar.

In this paper the results obtained in three existing plan irregular buildings, using the extended N2 method and the extended CSM-FEMA440 to plan asymmetric structures, are compared with the nonlinear dynamic median results and with the linear response spectrum analysis. The application of torsional correction factors to improve the performance of existing code pushover methodologies in estimating the seismic response of such structures is therefore evaluated.

In the first part of the work, the extension of both code procedures to the 3D case is described. Afterwards, the three case studies analysed, their modelling options as well as the seismic action considered are depicted. The results obtained with the evaluated procedures are presented in terms of normalized top displacements in order to better understand the torsional response of the buildings. Final conclusions are pointed out in the end.

2 Torsional correction factors to use in pushover methods

Extensive parametric studies have been performed by Fajfar and his co-workers [1] in order to investigate the parameters that influence the inelastic torsional response of building structures. Several conclusions were drawn and are herein presented:

- 1) The inelastic torsional response is qualitatively similar to the elastic torsional response. Quantitatively, the torsional effects depend on the ductility demand, therefore on the ground motion intensity;
- 2) An upper bound of the torsional amplifications can be estimated with a linear dynamic response spectrum analysis;
- 3) The torsional effects decrease with the increase of plastic deformations. This trend is clear with the smaller amplification of displacements on the flexible side. However, if the structure is subjected to small plastic deformations, characterized by ductility less than 2.0, the amplification on the flexible edge may be slightly higher than in the elastic structure;
- 4) The response on the stiff edge depends on the influence of different modes of vibration and on the ground motion in the transverse direction. This response depends on the structural and ground motion characteristics in both directions. It is difficult to make general conclusions about the response on the stiff side. De-amplification of displacements due to

torsion on the stiff side decreases with increasing plastic deformations in elastic torsionally stiff structures. Sometimes, it could happen a transition from de-amplification to amplification. In elastic torsionally flexible structures the amplification due to torsion decreases with increasing plastic deformations;

- 5) For large plastic deformations, the smaller torsional effects in the inelastic range when compared with the elastic range are usually illustrated by a flattening of the displacement envelopes in the horizontal plane;
- 6) The dispersion of results is larger in the inelastic range than in the elastic regime.

Based on the results obtained, the following conclusions were taken [1]. They are important for the development of simplified analysis methods and code guidelines:

- 1) A conservative estimation of the amplification of displacements due to torsion in the inelastic range can be determined by a dynamic elastic analysis;
- 2) Any reduction of displacements on the stiff side compared to the counterpart symmetric building, obtained from elastic analysis, will decrease or even disappear in the inelastic range.

These conclusions were used by Fajfar and his team [1, 12] to develop an extension of the N2 method to plan asymmetric building structures. The entire procedure can be summarized in the following steps:

- 1) Perform pushover analyses with positive and negative sign for each X and Y direction of a 3D numerical model. Compute the target displacement – displacement demand at the CM at roof level – for each direction as the larger value of the + and – sign pushover, using the original N2 method proposed in Eurocode 8;
- 2) Perform a linear modal response spectrum analysis in two X and Y direction combining the results according to the SRSS rule;
- 3) Determine the torsional correction factors. This factor is computed by the ratio between the normalized roof displacements obtained by the elastic response spectrum analysis and by the pushover analysis. The normalized roof displacement is obtained by normalizing the displacement value at a specific location with respect to those of the centre of mass (CM). If the normalized roof displacement obtained from the elastic response spectrum analysis is smaller than 1.0, one should consider 1.0 to avoid any favourable torsional effect (reduction of displacements) given by the elastic analysis;
- 4) Multiply the quantity under study at a certain location by the correction factor calculated for that location.

As one can conclude from the previous steps, the extended N2 method uses both nonlinear static pushover and elastic dynamic analysis. The displacement demand and its distribution along the height at the centre of mass of each storey are determined using the original N2 method. The amplification of displacements due to torsion is calculated by elastic dynamic analysis. The reduction of displacements due to torsion is not taken into account. The results obtained by Fajfar and his team show that this extended procedure leads to conservative estimations of the torsional response of plan asymmetric buildings.

In [13] Bhatt and Bento have extended the CSM-FEMA440 to plan asymmetric buildings following the aforementioned procedure suggested by Fajfar. The difference lies in step 1), where the target displacement is calculated using the CSM with the features proposed in FEMA440.

3 Case studies

Three real plan-asymmetric RC buildings were analysed in this endeavour. The first case study is the three storey SPEAR building. It represents typical existing three-storey buildings in the Mediterranean region following Greece's concrete design code in force between 1954 and 1995. This structure was designed only for gravity loads based on the construction practice applied in the early 1970s that included the use of smooth rebars. A prototype was tested in full scale at Ispra within the European framework project SPEAR. Further details on the structure and its pseudo-dynamic testing can be found in [14] and [15]. The SPEAR building is plan-asymmetric in both X and Y directions but it is regular in elevation (Figure 1).

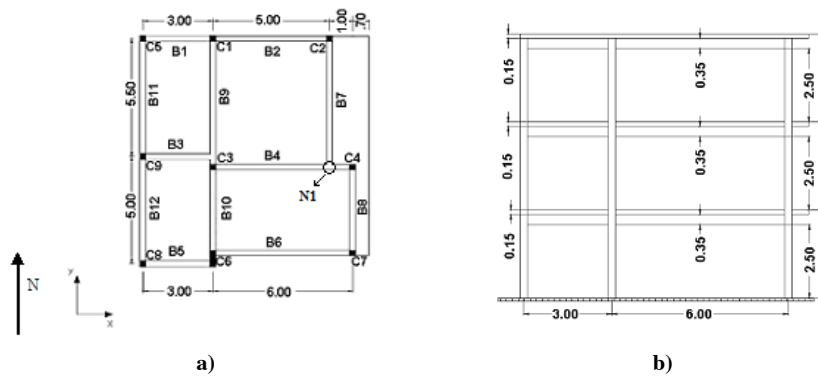

Fig. 1: Three storey building configuration: a) in plan; b) at the south west facade (units in meters).

The second case study is a five storey building. It is a real Turkish reinforced concrete structure which experienced the 1999 Golcuk earthquake without any damage. The building is asymmetric along the X axis, Figure 2a), and all the floors keep the same height, Figure 2b). There are potential weak connections due to the existence of beams framing into beams. There are also walls and elongated columns (wall-like column), as presented in Figure 2a). For more details on the building's characteristics see [16].

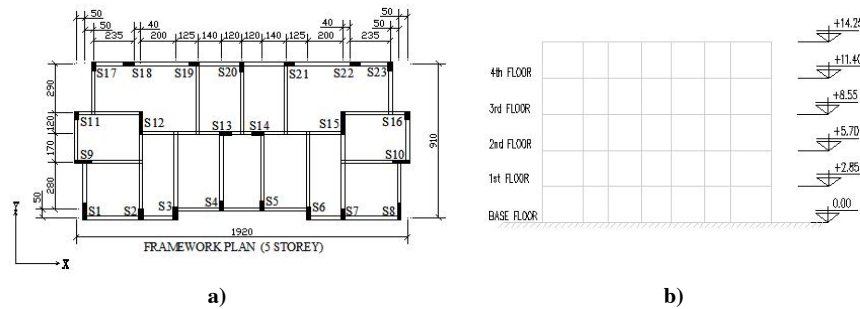

Fig. 2: Five storey building configuration (a) Plan View (cm), (b) Lateral View (m).

The last case study is a real 8 storey Turkish reinforced concrete building [17]. It is a plan-asymmetric structure in both X and Y axis, see Figure 3a). The first storey is 5.0m height and the upper floors are 2.7m height, Figure 3b). There are beams framing into beams leading to possible weak connections in the structure. There are also walls and elongated columns (wall-like column), as presented in Figure 3a), with the higher dimension always along the Y direction. For this reason, the structure will be more stiff and resistant along the Y direction.

The Turkish five and eight storey buildings were designed according to the 1975 Seismic Code of Turkey.

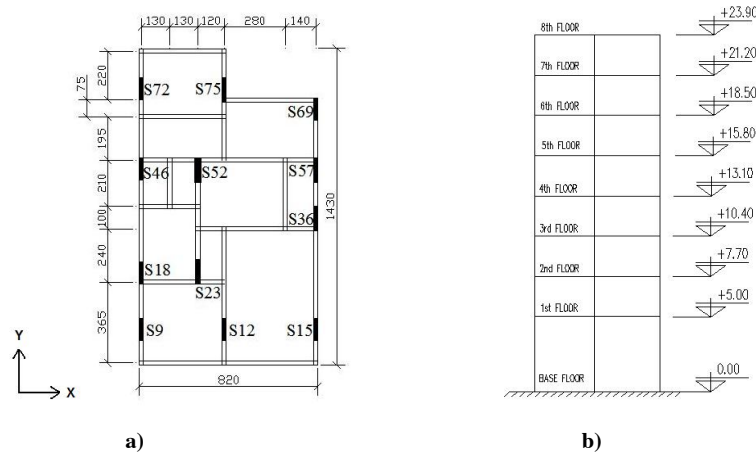

Fig. 3: Eight storey building configuration (a) Plan View (cm), (b) Lateral View (m).

4 Modelling options

The 3D models representing the buildings under analysis were developed with the fibre element based finite element program SeismoStruct [18]. They were built using space frames assuming the centrelines dimensions. The inelastic behaviour of the structural elements was modelled using a fibre element model, with each fibre being characterised by the material relationships described below.

The concrete was represented by a uniaxial model that follows the constitutive relationship proposed by Mander et al. [19] and the cyclic rules proposed by Martinez-Rueda and Elnashai [20]. The confinement effects provided by the lateral transverse reinforcement are taken into account through the rules proposed by Mander et al. [19] whereby constant confining pressure is assumed throughout the entire stress-strain range. A compressive strength of 25MPa was considered for the SPEAR building and 16.7MPa for the Turkish buildings. The constitutive model used for the steel was the one proposed by Menegotto and Pinto [21] coupled with the isotropic hardening rules proposed by Filippou et al. [22]. The average yield strength of 360 MPa was assumed for the SPEAR building and 371 MPa for the Turkish buildings.

The rigid diaphragm modelling calibration of the SPEAR building can be found in [23]. The comparisons between the analytical results and the experimental tests for this structure are described in Bento et al. [24].

5 Seismic assessment

In this section the parametric study is described, as well as the seismic action definition and the numerical model used in the performed structural analyses.

5.1 Seismic action

Seven bi-directional semi-artificial ground motion records from the SPEAR project fitted to the EC8 [7] elastic design spectrum (Type 1 soil C) were used in the three storey building case. For the five and eight storey buildings, combinations of three bi-directional semi-artificial ground motion records were applied. The three considered ground motions are real records from the PEER's database website [25]. They were fitted to the Eurocode 8 elastic design spectrum (with the Turkish code features – Type 1 soil A) using the software RSPMatch2005 [26].

The ground motions were scaled and applied for a wide range of peak ground intensities in order to assess the performance of the NSPs throughout different levels of structural inelasticity. The accelerograms were scaled for peak ground accelerations of 0.05, 0.1, 0.2 and 0.3g for the three storey building and to 0.1, 0.2, 0.4, 0.6 and 0.8g for the Turkish buildings. The median displacement response spectra of each set of ground motions were used to compute the nonlinear static procedures response. They are represented in Figure 4a) and b) as defined for the

three storey building and for the Turkish buildings respectively. In these figures are also plotted the EC8's response spectra with which the real accelerograms were matched.

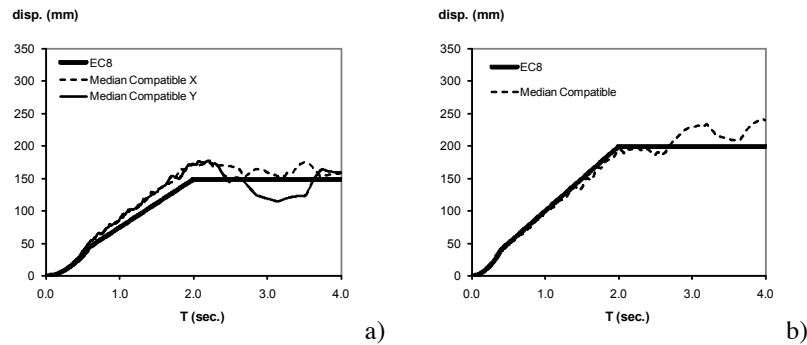

Fig. 4 – Displacement response spectra a) three storey, b) five and eight storey buildings.

5.2 Structural analyses performed

In the pushover analyses, lateral forces were applied to the structure in the form of modal load pattern (for the N2 method, a uniform distribution was also applied). The loads were applied independently in the two horizontal positive/negative directions, resulting in four analyses. For each one, the target displacement was computed with the larger value in each direction being chosen. The results were combined in the two directions using the SRSS combination.

For the nonlinear dynamic analysis of the 3 storey SPEAR building the aforementioned seven bidirectional semi-artificial ground motion records were applied in 4 different configurations: X+Y+, X+Y-, X-Y-, X-Y+.

For the nonlinear dynamic analysis of the Turkish buildings, the abovementioned three bidirectional semi-artificial ground motion records were used. Each record was applied twice in the structure changing the direction of the components, resulting in 6 models, each one with five intensity levels for the 5 storey building and three intensity levels for the 8 storey building.

The results in terms of normalized top displacements in the two directions were calculated and compared for all seismic intensity levels, and for all nonlinear static and dynamic analyses.

6 Dynamic properties of the case studies

The modal properties of the three analysed buildings are herein presented. The three storey building has a fundamental mode of 0.617sec characterized by translation along the X direction, a second mode of 0.527sec with torsional motion and a third mode of 0.441sec with translation along the Y direction. It is mentioning

that, in this case study, both translational modes are coupled with torsion. The five storey building presents a first mode of 0.617sec with translation along the X direction, a second mode of 0.593sec with translation along the Y direction and a third mode of 0.509sec with torsional motion. Finally the eight storey building has a first mode of 1.445sec with translation along the X direction, a second mode of 0.636sec with torsional motion and a third mode of 0.482sec with translation along the Y direction. Further details on the modal results can be found in [27].

The analysed buildings present torsional features due to their irregularities in-plan. According to Fajfar [1] the period ratios of a structure have an important influence on its torsional behaviour. The period ratios Ω_x and Ω_y are defined as the uncoupled translational period divided by the uncoupled torsional period in the X and Y directions. The influence of the predominantly torsional mode of vibration on the response in the direction considered when compared with the predominantly translational mode increases if the period ratio decreases. Structures with period ratios larger than 1 are usually classified as torsionally stiff and structures with period ratios smaller than 1 as torsionally flexible. A structure can be torsionally stiff in one direction and torsionally flexible in the other. In Table 1 are represented the period ratios in the X and Y direction for the three analysed buildings. One can conclude that the three storey building is classified as torsionally stiff in the X direction and torsionally flexible in the Y direction. The five storey building is torsionally stiff in both X and Y direction. The eight storey building is torsionally stiff in the X direction and torsionally flexible in the Y direction.

Table 1 Period ratios.

	Ω_x	Ω_y
3 storey building	1.2	0.8
5 storey building	1.2	1.2
8 storey building	2.3	0.8

7 Results of the parametric studies

The results obtained with the extension of the N2 method and of the CSM-FEMA440 for plan asymmetric buildings are plotted against the median time-history nonlinear dynamic results (TH), the response spectrum analysis (RSA) and the original procedures, in terms of normalized top displacements. When dealing with plan-asymmetric buildings the normalized top displacements is the measure one should analyse in order to understand the torsional behaviour of the structure [1]. This measure is obtained by normalizing the edge displacement values with respect to those of the centre of mass. Several plots are presented showing the performance of the analysed procedures in estimating the torsional motion of the evaluated buildings.

In Figures 5 and 6 and 7 are depicted the results of the extended N2 method and in Figures 8, 9 and 10 are presented the results of the extended CSM-FEMA440, for the three analysed buildings, for different seismic intensities. More results on the performance of the extended N2 method and of the extended CSM-FEMA440 can be found in [27] and in [13] respectively.

From the obtained results, one can observe that the two original N2 and CSM-FEMA440 methods lead to similar normalized top displacements in the three analysed buildings. The same happens with both extended procedures.

One can conclude that torsional effects are generally higher for lower ground motion intensities. For increasing seismic intensities, one can understand a flattening on the normalized top displacements. This can be observed in all the analysed buildings. This conclusion confirms the idea that torsional effects are generally smaller in the inelastic range compared to what happens in the elastic one.

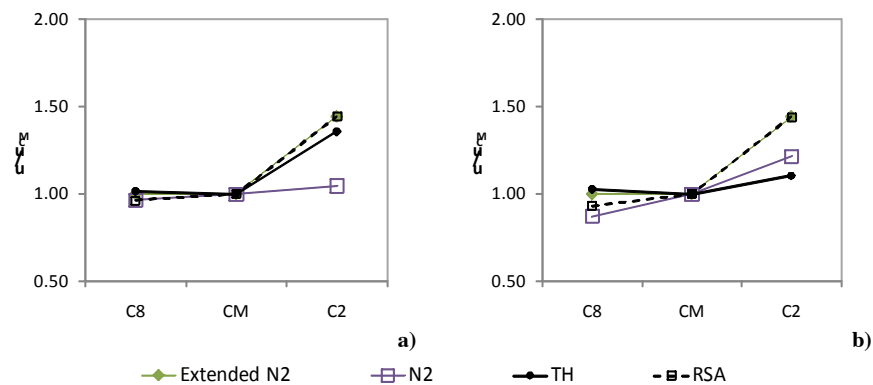

Fig. 5 – Normalized top displacements, three storey building a) X direction, 0.1g, b) Y direction, 0.2g.

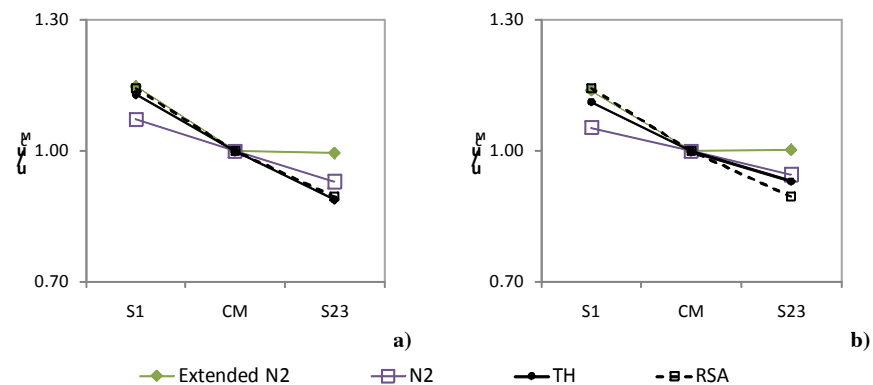

Fig. 6 – Normalized top displacements, five storey building a) X direction, 0.2g, b) X direction, 0.6g.

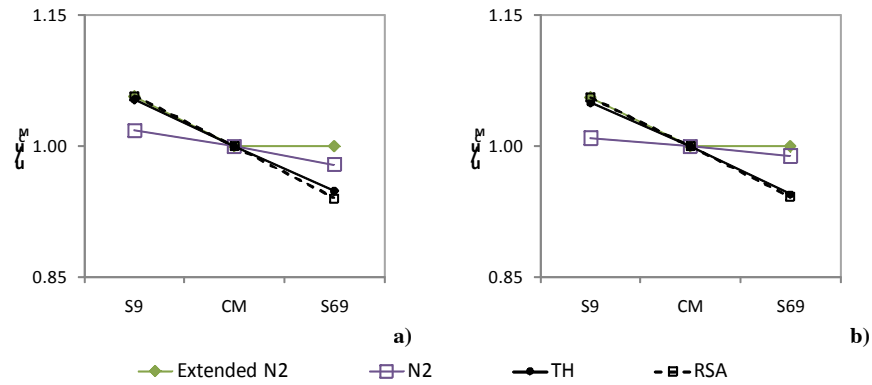

Fig. 7 – Normalized top displacements, eight storey building a) X direction, 0.2g, b) X direction, 0.4g.

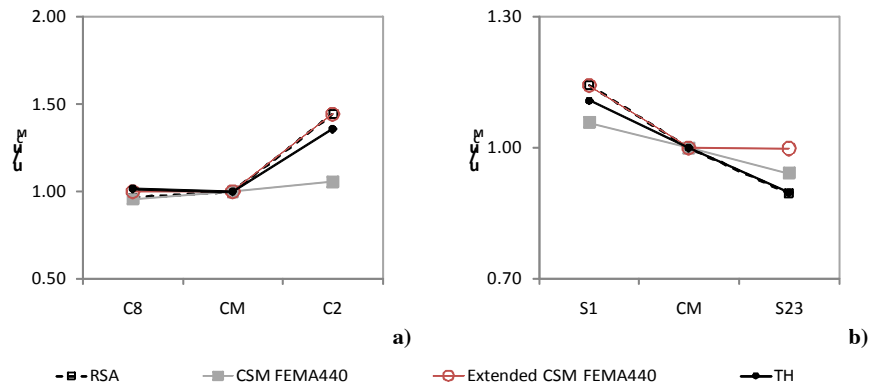

Fig. 8 – Normalized top displacements a) three storey building, X direction, 0.1g, b) five storey building, X direction, 0.1g.

The plots clearly show that the RSA estimates an upper bound of the torsional amplification on the flexible side of the buildings, in both elastic and inelastic range.

The extended procedures reproduce in a very good fashion the nonlinear dynamic results for all the buildings analysed and through all the seismic intensities tested. These methods show, for these case studies, a much better performance in estimating the torsional behaviour of the buildings than the original methods. Generally the last ones are not capable to reproduce the torsional response of the buildings.

The abovementioned plots show that the extended methods reproduce in a very accurate way the torsional amplification on the flexible edge in all the buildings analysed through all the increasing intensities. This good performance is justified because these extended procedures use a correction factor based on a RSA which also leads to very good estimations of the torsional amplifications, as shown in the

plots. The original methods generally underestimate the torsional amplification of the displacements on the flexible side.

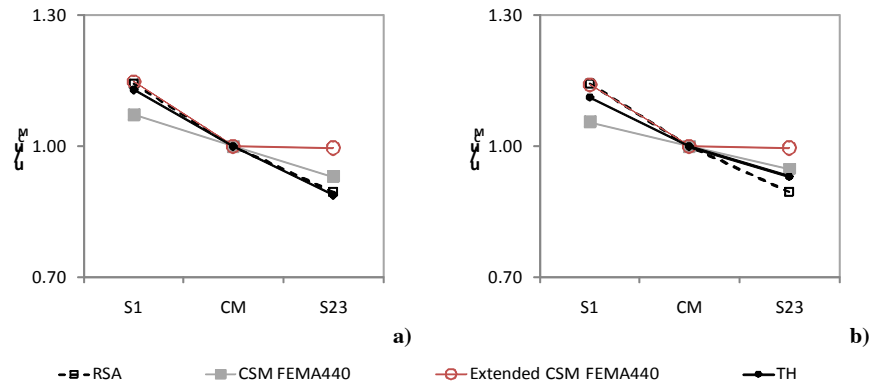

Fig. 9 – Normalized top displacements, five storey building a) X direction, 0.2g, b) X direction, 0.6g.

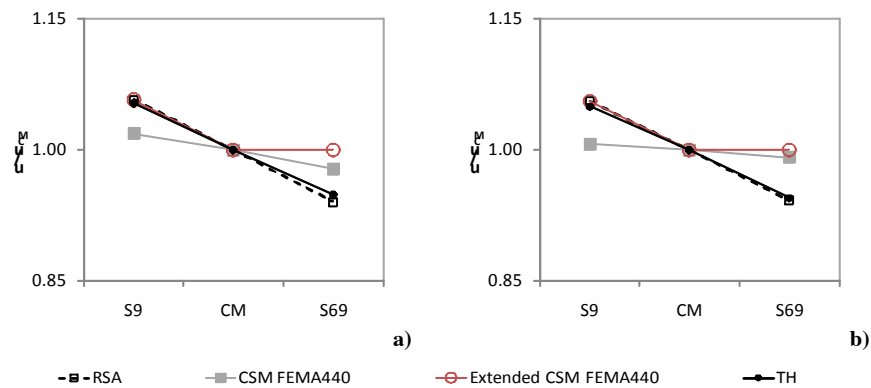

Fig. 10 – Normalized top displacements, eight storey building a) X direction, 0.2g, b) X direction, 0.4g.

From the plots it is evident that both RSA and the original methods consider the torsional de-amplification on the stiff side of the buildings, leading in some cases to underestimated results. For example, Figure 5b) (column C8), Figure 6b) (column S23) and Figure 7a) (column S69) illustrate the cases where the RSA leads to normalized top displacements smaller than one on the stiff edge, being these results non-conservative when compared with the timehistory. Therefore, whenever the RSA leads to normalized top displacements smaller than one, the extended methods consider this value to be equal to one. This recommendation avoids the extended methods to produce non-conservative results on this stiff edge. One can say that this is a safe criterion for designing and assessment of structures. In fact it must not be forgotten that this simplified procedures are de-

veloped to be applied in design offices where the results should rather be conservative than almost close to timehistory but slightly underestimated.

The original methods always provide a linear estimation of the torsional motion from one side of the building to the other, through all the seismic intensities. The extended methods do not consider any de-amplification of displacements due to torsion, leading in some cases to very accurate results and in others to conservative responses on the stiff edge of the buildings.

The results obtained in this paper seem quite optimistic regarding the implementation of the extended N2 procedure in Eurocode 8 and of the extended CSM-FEMA440 in the next version of ATC guidelines.

However, one should be aware that the interplay among ground motion, inelastic amplification or de-amplification of displacements and structural system is complex. Therefore, more studies in different buildings should be developed in order to consolidate these nonlinear static approaches.

8 Conclusions

In this work, the torsional seismic response of plan irregular buildings was assessed using pushover code procedures – N2 method (Eurocode 8) and CSM (FEMA440) – and their extensions to the 3D case. These improvements are based on torsional correction factors, which depend on a pushover analysis and on a linear dynamic response spectrum analysis. The results obtained with the evaluated NSPs were compared with the nonlinear dynamic analysis and with the linear response spectrum analysis. The case studies evaluated were three existing plan irregular buildings with three, five and eight storeys. The procedures were evaluated by comparing the results in terms of normalized top displacements of the three case studies for different ground motion intensities. This measure gives an idea about the torsional behaviour of the structures.

The results obtained from this study showed that torsional effects are in general higher for lower ground motion intensities. In fact, for increasing seismic intensities, one can notice a flattening on the normalized top displacements of each building. This confirms the idea that torsional effects are generally smaller in the inelastic range than in the elastic stage.

The extended methods performed in a much more accurate way than their original counterparts in estimating the torsional behaviour of all buildings analysed through all the seismic intensities tested. They generally captured in a very precise way the torsional amplification in terms of displacements on the flexible side of the buildings.

The extended procedures do not take into account any de-amplification of displacements due to torsion. Therefore, the response on the stiff side of the buildings was in some cases estimated in a very precise way by the methods, and overestimated in others.

The original methods are not capable in general to reproduce the torsional motion of the buildings, usually leading to a linear estimation of the torsional motion from one side of the building to the other.

The original procedures considered the de-amplification on the stiff side of the buildings, underestimating in some cases the response. On the flexible side, the normalized top displacements were generally non-conservative in respect to the timehistory results.

Recently, several procedures have been proposed taking into account torsion in simplified nonlinear static procedures, however definitive answers have not yet been reached. The results obtained herein added to the ones already published [1, 12, 3, 27, 28], confirm the idea that the extended N2 method has potential to be implemented in the next version of Eurocode 8 in order to correctly estimate the torsional response in real plan-asymmetric RC buildings through the use of pushover analysis.

The extension of the CSM-FEMA440 also presents potential to be incorporated in future codes, namely the ATC guideline. However, this procedure should be further tested in order to consolidate definitive conclusions.

Acknowledgments The authors would like to thank Dr. Ihsan Bal for providing valuable data related to research work on the topic of this article. A special acknowledgment to Dr. Rui Pinho for the valuable discussions that certainly enriched the work herein presented. The authors would like to acknowledge the financial support of the Portuguese Foundation for Science and Technology (Ministry of Science and Technology of the Republic of Portugal) through the research project PTDC/ECM/100299/2008 and through the PhD scholarship SFRH/BD/28447/2006 granted to Carlos Bhatt.

References

- [1] Fajfar P., Marusic D., Perus I. (2005) Torsional effects in the pushover-based seismic analysis of buildings. *Journal of Earthquake Engineering* 9(6): 831-854.
- [2] Chopra A.K., Goel R.K. (2004) A modal pushover analysis procedure to estimate seismic demands for unsymmetric-plan buildings. *Earthquake Engineering and Structural Dynamics* 33: 903-927.
- [3] D'Ambrisi A., Stefano M., Tanganelli M. (2009) Use of Pushover Analysis for Predicting Seismic Response of Irregular Buildings: a Case Study. *Journal of Earthquake Engineering* 13: 1089-1100.
- [4] Erduran E., Ryan K. (2011) Effects of torsion on the behaviour of peripheral steel-braced frame systems. *Earthquake Engineering and Structural Dynamics* 40(5): 491-507.
- [5] Fajfar P., Fischinger M. (1988) N2 - A method for non-linear seismic analysis of regular buildings. *Proceedings of the Ninth World Conference in Earthquake Engineering*, pp. 111-116. Tokyo-Kyoto, Japan.
- [6] Fajfar P. (2000) A nonlinear analysis method for performance-based seismic design. *Earthquake Spectra* 16(3): 573-592.
- [7] CEN, Comité Européen de Normalisation (2004) Eurocode 8: Design of structures for earthquake resistance. Part 1: general rules, seismic actions and rules for buildings. EN 1998-1:2004. Brussels, Belgium.

- [8] Freeman S.A., Nicoletti J.P., Tyrell J.V. (1975) Evaluation of existing buildings for seismic risk - A case study of Puget Sound Naval Shipyard, Bremerton, Washington. Proceedings of U.S. National Conference on Earthquake Engineering, pp. 113-122. Berkeley, USA.
- [9] Freeman S.A. (1998) Development and use of capacity spectrum method. Proceedings of the Sixth U.S. National Conf. Earthquake Engineering. Seattle, Oakland, USA.
- [10] ATC, Applied Technology Council (1996) Seismic Evaluation and Retrofit of Concrete Buildings, vol. 1 and 2, Report No. ATC-40. Redwood City, CA.
- [11] ATC (2005) Improvement of Nonlinear Static Seismic Analysis Procedures, FEMA440 Report. Redwood City, CA.
- [12] Fajfar P., Marušić D., Perus I. (2005) The extension of the N2 method to asymmetric buildings. Proceedings of the 4th European workshop on the seismic behaviour of irregular and complex structures. Thessaloniki.
- [13] Bhatt C., Bento R. (2011) Extension of the CSM-FEMA440 to Plan-Asymmetric Real Building Structures. *Earthquake Engineering and Structural Dynamics* 40(11): 1263-1282.
- [14] Fardis, M.N. (2002) Design of an Irregular Building for the SPEAR Project -Description of the 3-Storey Structure. Research Report. University of Patras, Greece.
- [15] Fardis M.N., Negro P. (2006) SPEAR - Seismic performance assessment and rehabilitation of existing buildings. Proceedings of the International Workshop on the SPEAR Project. Ispra, Italy.
- [16] Vuran E., Bal Y.E., Crowley H., Pinho R. (2008) Determination of equivalent SDOF characteristics of 3D dual structures. Proceedings of the 14th World Conference on Earthquake Engineering, pp. S15-031. Beijing, China.
- [17] Bhatt C., Bento R., Pinho R. (2010) Verification of nonlinear static procedures for a 3D plan-irregular building in Turkey. Proceedings of the 14th European Conference on Earthquake Engineering. Ohrid, Macedonia.
- [18] Seismosoft (2006) Seismostruct - A computer program for static and dynamic nonlinear analysis of framed structures. Available online from URL: www.seismosoft.com.
- [19] Mander J.B., Priestley M.J.N., Park R. (1988) Theoretical stress-strain model for confined concrete. *ASCE Journal of Structural Engineering* 114(8): 1804-1826.
- [20] Martinez-Rueda, J.E., Elnashai, A.S. (1997) Confined concrete model under cyclic load. *Materials and Structures* 30(197): 139-147.
- [21] Menegotto M., Pinto P.E. (1973) Method of analysis for cyclically loaded RC plane frames including changes in geometry and non-elastic behaviour of elements under combined normal force and bending. Symposium on the Resistance and Ultimate Deformability of Structures anted on by well defined loads, International Association for Bridges and Structural Engineering, pp. 15-22. Zurich, Switzerland.
- [22] Filippou F.C., Popov E.P., Bertero V.V. (1983) Modelling of R/C joints under cyclic excitations. *Journal of Structural Engineering* 109(11): 2666-2684.
- [23] Pinho R., Bhatt C., Antoniou S., Bento R. (2008) Modelling of the horizontal slab of a 3D irregular building for nonlinear static assessment. Proceedings of the 14th World Conference on Earthquake Engineering, pp. 05-01-0159. Beijing, China.
- [24] Bento R., Bhatt C., Pinho R. (2010) Using Nonlinear Static Procedures for Seismic Assessment of the 3D Irregular SPEAR Building. *Earthquakes and Structures* 1(2): 177-195.
- [25] PEER (2009) Strong Ground Motion Database, Available from: <http://peer.berkeley.edu/nga/>. 2009.
- [26] Hancock J., Watson-Lamprey J., Abrahamson N.A., Bommer J.J., Markatis A., McCoy E., Mendis R. (2006) An improved method of matching response spectra of recorded earthquake ground motion using wavelets. *Journal of Earthquake Engineering* 10(S1): 67-89.
- [27] Bhatt C, Bento R. (2011) Assessing the Seismic Response of Existing RC Buildings Using the Extended N2 Method. *Bulletin of Earthquake Engineering* 9(4): 1183-1201.
- [28] Koren D., Kilar V. (2011) The applicability of the N2 method to the estimation of torsional effects in asymmetric base-isolated buildings. *Earthquake Engineering and Structural Dynamics* 40(8): 867-886.